

20/50 litres



Translated from Original

Operating/ Brewing Instructions
for
Speidels Braumeister

Item no.: 47070, 45050



Version February 2011



1	GENERAL.....	3
2	SAFETY NOTES:	3
2.1	General safety notes	3
2.2	Special safety notes	4
3	COMPONENTS AND SCOPE OF DELIVERY	5
4	TECHNICAL SPECIFICATIONS FOR BRAUMEISTER.....	5
5	SETTING UP THE BRAUMEISTER	6
6	CLEANING THE BRAUMEISTER	6
7	STORING THE BRAUMEISTER	6
8	PRIOR TO FIRST USE	6
9	DISPOSAL.....	7
10	WORKING WITH THE BRAUMEISTER	8
10.1	Language selection.....	8
10.2	Notes on temperature control	8
10.3	Notes on the circulating pump	8
10.4	Notes on the container lid.....	9
10.5	Notes on hygiene	9
11	BREWING WITH THE BRAUMEISTER	10
11.1	Introduction	10
11.2	Preparations	10
11.3	Programming/ starting automatic brewing	11
11.4	Mashing	11
11.5	Purification.....	13
11.6	Hops boiling.....	14
11.7	Cooling.....	15
11.8	Main fermentation	16
11.9	Maturation	17
12	BREWING EXAMPLE/ BRIEF INSTRUCTIONS	18
13	BREWING FAULTS/ TROUBLESHOOTING	21
14	LEGAL ASPECT OF HOME BREWING	23
15	BREWING RECORD	24
16	CLEANING INSTRUCTIONS.....	25
17	GUARANTEE CONDITIONS, HANDLING A GUARANTEE	27

1 General

Dear customer

You have purchased a new device from our company. Many thanks for trusting in us. Quality and functionality of our products rate high on our list of priorities.

Use according to intended purpose:

The Braumeister has been designed and produced for brewing smaller quantities (approx. 20l / 50l) of beer. Prior to each brewing procedure, a safety inspection must be performed for proper functionality of the Braumeister.



Operating instructions:

These operating and brewing instructions have been compiled to ensure reliable and safe commissioning and operation of the Braumeister right from the start. Please read the instructions carefully and in full before brewing your first beer. Compliance with these notes and instructions will ensure that your Braumeister operates to your utmost satisfaction, and has a long lifespan. Weight and volume indications are always for 20l/50l. The first specification applies to the 20l Braumeister and the second to the 50l Braumeister.



Conformity declaration:

SPEIDEL Tank- und Behälterbau GmbH hereby declares that the “Braumeister” product mentioned in these instructions and to which this declaration applies complies with the regulations of the following European guidelines:
EMC 2004/108/EC, Low Voltage 2006/95/EC

Manufacturer:

Speidel Tank- und Behälterbau GmbH
Krummenstrasse 2
72131 Ofterdingen
Germany
www.speidels-braumeister.de
www.speidel-behaelter.de

2 Safety notes:

2.1 General safety notes



- The device and mains cable must be inspected regularly for any signs of damage. In the event of signs of damage, the device may no longer be used.
- Always disconnect the plug from the socket (pull the plug, not the cable) if you no longer wish to use the device, for cleaning or in the event of a fault.
- Ensure that you lay the mains cable such that it does not come into contact with sharp objects. The cable must be fully unwound.
- Where extension cables are used, these must have the same wire gauge and also be fully unwound. Do not use multi sockets as the output of this device is too high. Overloading the electric fuse must be avoided. As the Braumeister requires extra power, do not switch any additional “large consumers” to the same fuse. **Fire hazard!**

- The Braumeister may only be used as intended and in a safe, fault-free condition. Ensure that you check the proper condition prior to each use.

Children and frail persons:



- For the safety of your children, do not allow packaging parts (cartons, polystyrene etc.) to be readily accessible. Do not allow small children to play with foil. A **risk of suffocation** exists!
- This device is not meant to be handled by persons (including children) with limited physical, sensory or mental capabilities, or lack of experience and/or know-how, unless they are being supervised by a person responsible for their safety or have received instructions on how to use the device.
- Children should be supervised to ensure that they are kept away from the device and do not play with the device.

2.2 Special safety notes



- The container, lid and add-on parts reach an extremely high temperature. Towards the end of the brewing process, the boiler contains boiling beer wort. Pay attention to the notes on setup. Never move the Braumeister in a hot state. Always use pot holders or gloves when working on and with the Braumeister. **Risk of burning!**



- When lifting the lid, ensure that the condensation on the underside of the lid flows back into the container. For this, hold the lid over the container at an angle. **Scalding risk!**



- When performing cleaning activities on the Braumeister always ensure that the plug is disconnected (disconnection from mains). Do not spray the device down or allow spray to come into contact with electric components. **Danger of electric shock!**



- Important: It is imperative that you secure the plug connections at the rear of the device (pump and heating) during operation of the device. Operating the device without securing plug and socket devices can lead to overheating. **Fire hazard!**
- Please use the **thermal sleeve** available as an accessory for insulation. When using your own insulation ensure that the electronics and the lower part of the Braumeister are sufficiently ventilated, as a heat build-up and damage to the control may otherwise occur.
- The pump must be vented prior to each use to prevent dry running. Venting takes place routinely in automatic operation. In manual operation, the pump must be switched on and off several times until no more air bubbles escape.

3 Components and scope of delivery

Please refer to the following illustration for components and the scope of delivery (cooling coil and fermentation vessel not included): The 50l Braumeister is operated with 2 circulation pumps and 2 heating coils, and has an additional handle on the rear (not illustrated here).

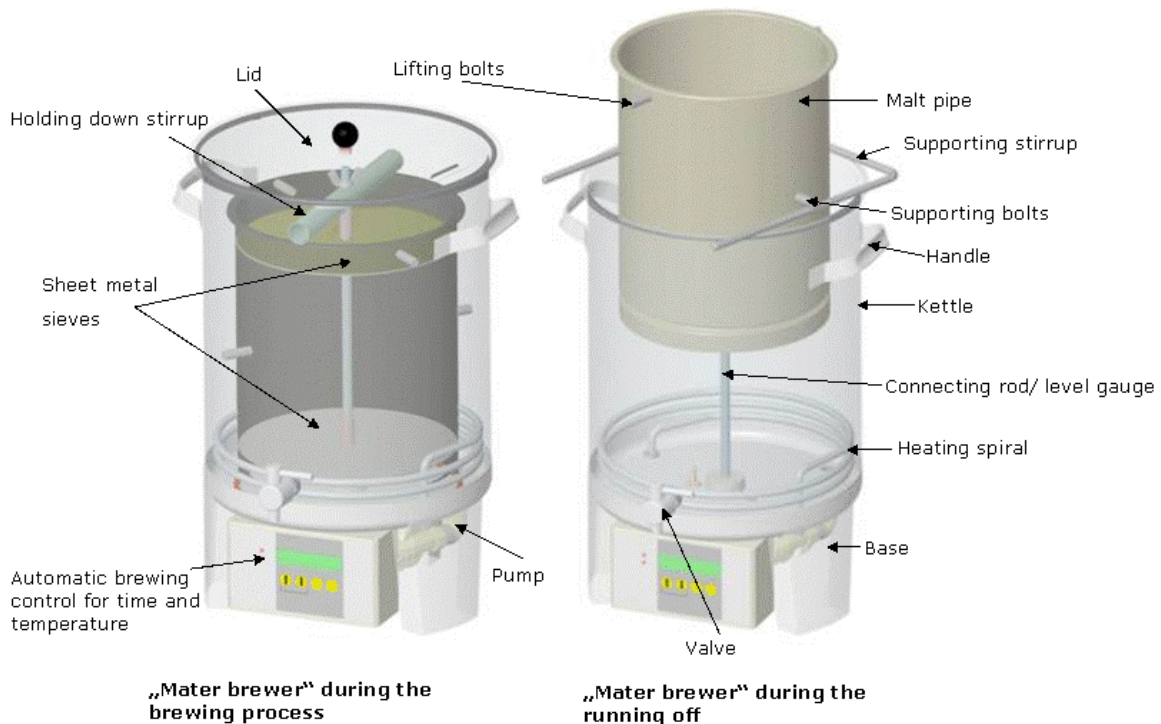

4 Technical specifications for Braumeister

Braumeister 20l

Weight:	15 kg including internal fittings and lifting bows
Heating coil:	2000 Watt heating capacity
Pump :	1 x 23 Watt
Power connection:	230 V ~
Min. fuse protection:	10 Amp
Contents	Brewing quantity approx. 20l ready-to-drink beer (regular beer) = approx. 23l beer wort
Max. filling level:	Upper marking on tie rod = 25l

Braumeister 50l

Weight:	24 kg including internal fittings and lifting bows
Heating coil:	3200 Watt heating capacity
Pump:	2 x 23 Watt
Power connection:	230 V ~
Min. fuse protection:	16 Amp
Contents:	Brewing quantity approx. 50l ready-to-drink beer (regular beer) = approx. 53l beer wort
Max. filling level:	Upper marking on tie rod = 55l

5 Setting up the Braumeister



The Braumeister must be positioned on a stable, secure and horizontal support structure prior to use. Take note that the Braumeister can weigh up to 50kg/ 90kg in a filled state and that it contains boiling hot beer wort. Horizontal positioning is a prerequisite for transfer pumping during the brewing process. Avoid an unsteady base. Most suitable are a stable wooden box or a table that is not too high. The Braumeister may not be moved during the brewing process. The handles are only meant for transporting the device in an empty state. It is imperative to keep children and frail persons away from the device while it is in operation.

6 Cleaning the Braumeister

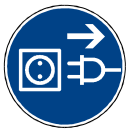

The Braumeister must be cleaned immediately after the brewing process. Avoid surface drying of wort and malt remnants, as this will significantly impair the cleaning process. All stainless steel components can be cleaned using a conventional detergent. Abrasive agents and sponges/brushes that cause scratching are not suitable. Ideally use a pipe cleaner thread to clean the heating coil. The pump and its internal drive ball should also be rinsed regularly. For this, simply turn the Braumeister upside down and loosen the screws, which should at all times only be hand tightened. The pump can be removed completely from the Braumeister by simply loosening the plug screws. When cleaning the brewing vessel ensure that no water spray or moisture comes into contact with the electrical components. The current supply must be disconnected for performing cleaning activities on the Braumeister. Before starting the brewing process, remove all dust and dirt from the Braumeister and all internal fittings by means of warm water. Also rinse the pump and lines by means of transfer pumping. Caution: If you allow the pump to run longer than a few seconds for cleaning, ensure that it is sufficiently vented to avoid dry running (switching the pump on and off several times provides good venting). Ensure that you include the malt pipe seal and drainage tap as well. Make sure that no detergent remnants whatsoever remain in the Braumeister, as these could have a negative impact on the foam stability of the beer. Please refer to the detailed cleaning instructions on page 26 (cleaning set available as an accessory).

7 Storing the Braumeister

The Braumeister must be stored in a dry location. Avoid contact with ferrous or rusty objects.

8 Prior to first use

Clean the Braumeister thoroughly using lukewarm water prior to initial use (see Chapter 6). Also ensure that the Braumeister is securely set up as per Chapter 5. Confirm that the Braumeister is in proper condition. Also take notice of the safety notes in Chapter 2. For the rest, the Braumeister has been constructed for immediate commissioning.

9 Disposal



Meaning of the “refuse bin” symbol on the Braumeister: Protect our environment; electrical devices should not be disposed of as household refuse. Make use of collection points for disposal of electrical devices and hand in all electrical devices that you no longer wish to use at these points. In this manner, you can avoid a potential impact on the environment and human health caused by incorrect disposal. This is your contribution to recycling and other forms of use of waste electrical and electronic equipment. You can find information on where to dispose of the devices from your district or municipal administration.

10 Working with the Braumeister

10.1 Language selection

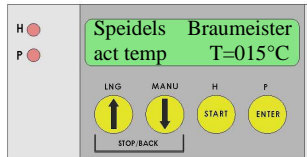

Press the UP ARROW (LNG) for 3 seconds to move from the basic setting to the language selection menu. Use the arrows to select between GERMAN, ENGLISH, FRENCH and SPANISH. Press enter to set the language selected.

10.2 Notes on temperature control

ARROW UP

- Increase time/ temp in programming mode and in manual operation
- Language settings (3 sec)
- Arrow up + arrow down = Stop automatic operation or return from manual operation

LED heating
LED pump

Display

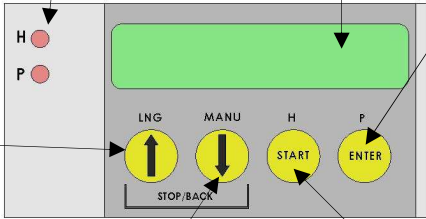

ENTER

- Change in programming mode (1 sec)
- Confirmation of values in programming mode
- Acknowledgement of prompts in automatic operation
- Pump On/Off in manual operation

ARROW DOWN

- Decrease time/ temp in programming mode and in manual operation
- Change in manual operation (1 sec)
- Arrow up + arrow down = Stop automatic operation or return from manual operation

START

- Starting automatic brewing (1 sec)
- Confirmation button during brewing process
- Heating On/Off in manual operation

Automatic operation: Begin with START (1 sec). A detailed description can be found in the chapter below – “Brewing with the Braumeister”.

Programming module: Use the ENTER button (1 sec) to enter programming mode. A detailed description can also be found in the chapter below – “Brewing with the Braumeister”.

Manual operation: Press the ↓ (1 sec) to go to manual operation of the Braumeister. Press START to switch the heating (H) on/off. Press ENTER to switch the pump (P). Set the temperature by means of the arrow keys. Return to the initial display of the Braumeister by simultaneously pressing ↓+↑.

Stop/ Back: Press the keys ↓+↑ simultaneously to return to the initial setting from all operation types (automatic, programming mode and manual operation).

10.3 Notes on the circulating pump

Switch the circulating pump on and off in manual operation using the “Enter” or “P” key. It is important to vent the pump in manual operation after filling it with liquid, so as to ensure that it does not run dry and possibly incur damage. This can be achieved by filling the pump with water and switching it on and off several times at an installation position of approx. 45° (until no more air bubbles escape and the sound of

the pump is almost inaudible). During the brewing process, the pump switches off automatically in manual operation for purposes of protection as soon as the temperature exceeds 88°C.

10.4 Notes on the container lid



The lid assists in reaching the temperatures more quickly in the heating up phase. The ventilation slits avoid pressure forming in the vessel and allow for light air circulation. Higher water temperatures cause condensation to occur on the underside of the lid. When lifting the lid, ensure that you hold the lid rim over the vessel opening (at an angle) so that the condensation can run back into the vessel.

10.5 Notes on hygiene

Hygiene is of top priority when brewing beer. Especially in the cold process area (while cooling off, when decanting and while fermenting), the beer and the wort are susceptible to infection, which causes the beer to spoil, meaning that all work could be in vain. For this reason, take particular care in ensuring that all containers (fermentation vessel, bottles) and work materials (spoon, taps, seals) are meticulously clean. Sulphuric acid or a similar substance is particularly suitable for disinfecting these containers and objects, and can be purchased at specialist winery shops and commercial outlets that specialise in hobby brewing equipment. Mix and dilute the powder with water and push this solution into the fermentation lock for disinfection of the fermentation vessel, all other equipment and even your hands. We recommend preparing a bucket with sulphuric acid, for example, and using this solution for disinfecting your hands and all equipment during the brewing process and prior to decanting. Fill the fermentation vessel with a little sulphuric acid and leave to stand for a few hours. Shake the vessel several times at intervals. Empty it and allow to drip-dry prior to use. Rinsing the vessel with water is not necessary. A few drops or a little residue of the sulphuric acid in the beer is completely harmless. Storage and maturation vessels are disinfecting in the same way as fermentation vessels. Where the beer is filled into flip-top bottles for maturation after fermenting, disinfect the bottles by heating in the oven. Remove rubber seals and disinfect by boiling in hot water or bathing in sulphuric acid. Heat the bottles in the oven until they reach a temperature of approx. 130°C. Then switch the oven off and allow the bottles to cool to room temperature again. Cap using the disinfected seals. In this manner you can ensure that the fermented beer is filled into meticulously clean bottles. The disinfection process should be performed a few days before the end of maturation, to ensure that the filling procedure can take place quickly and without rush.



11 Brewing with the Braumeister

11.1 Introduction

Making beer with the Braumeister can be split into different phases, whereby each phase is individually described below. To start off, all phases are described in general: The brewing procedure applies to all beer types and recipes. An actual brewing example for first-time brewers and a special recipe with precise indications of quantity, brewing times and temperature levels are provided in the chapters that follow. Before starting to brew beer, we recommend that you gain an overview of the individual steps required for preparing a ready-to-drink beverage. To ensure that you do not leave out any steps and to allow you to gain an overview of your brewing procedures in retrospect, we recommend keeping a brewing record (see Record in attachment or at www.speidels-braumeister.de). Another tip: Allow yourself a day for your first brewing attempt, and where possible have another person join you, as it is much more fun together and another set of hands can be very helpful. Note that brewing beer requires a little experience and that each brewing process is an improvement on the previous one. So don't be disappointed if your first beer does not quite meet your expectations. This is perhaps best illustrated by the words of a witty German poem that suggests that the beer from the first attempt is neither here nor there and is bound to cause flatulence, while the second is mediocre, causing you to pass more liquid than you consumed. The third attempt results in a true beer enjoyed by men and women alike:

„Das erste Bier ist ein Plempel,
der den Bauern d`Hosen z`sprengt:
Andern zum Exempel.
Das zweite ist ein Mittelbier,
Trinkst drei Maß, so pieselst vier.
Das dritte ist ein Bier vom Kern,
das trinken d`Herrn und d`Frauen gern.“

11.2 Preparations

Procuring the ingredients

Organise the required brewing ingredients (hops, malt and yeast) in good time. Ensure that the malt is fresh. After crushing the malt (breaking open the corns – not too fine) use it up as quickly as possible. Quantity indications vary according to recipe, whereby the malt quantity is between 4-5/ 9-11 kg and the hops quantity between 20-50/ 50-100 g. Hops is mostly available in a pressed form, as pellets. We recommend using dry yeast for fermentation as it can be more easily stored and has a longer shelf life. These ingredients are available at commercial outlets for hobby brewers and via the internet. A third option for procuring the ingredients is a brewery in your vicinity. Why not just ask?

Cleaning the devices

Before starting the brewing process, rinse the Braumeister with warm water and flush the pump by switching it on. All other equipment such as the beer spindle, wooden spoon and fermentation vessel should be ready for use and clean. See also the notes in the chapters “Notes on hygiene” and “Cleaning the Braumeister” in this regard.

Decalcifying the water for brewing

Where required, the brewing water can be decalcified. For this, boil the water (cold tap water) in the Braumeister for 30 minutes, allow it to cool and then store it temporarily, for example in the fermentation vessel, until you are ready to start brewing. Dispose of the precipitated calcium that has collected at the bottom of the container. The Braumeister is designed to brew approx. 20l/ 50l ready-to-drink beer (regular beer). You will need 25-30l/ 55-60l brewing water. However, normal (perfectly hygienic, colourless and odourless) cold tap water can also be used by beginners, that is, for first brewing attempts, to keep the effort slightly in check to start off with. In principle, the brewing water should display a hardness less than 14°dH. The softer the water, the better it is suited to brewing.

11.3 Programming/ starting automatic brewing

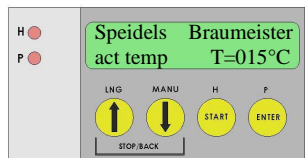

Plug in the Braumeister. The control is now in a basic state. Press the ENTER key for 1 second to program a recipe and its time and temperature values.

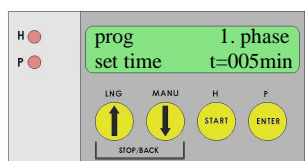

Use the ARROW KEYS to select the time and temperature, and confirm by pressing ENTER. You can program the mashing in, phases 1-5 and hops boiling in this manner. Rest 5 is set to 0 and is only used for special recipes.



After confirming all programming levels with ENTER, you will again find yourself in the basic state. Start automatic brewing from here by pressing the START key for 1 second. Then follow the instructions in the program.

11.4 Mashing

Mixing the malt grist with water is known as mashing. The aim of the entire mashing process is to separate the malt starch contained in the malt from the malt and to convert it into sugar with the help of the enzymes contained in the malt. The various enzymes act at different temperatures, which is why the process undergoes different temperature levels.

Mashing in

Start off by filling 23l/ 53l brewing water into the vessel (to approx. 2 cm below the upper marking). The malt pipe is not yet inserted. The markings on the tie rod indicate the filling level of 15l, 20l and 25l/ 45l, 50l and 55l. Press START to confirm that you have filled in water. This switches on the pump and the heating. The pump switches on and off several times for the purpose of venting.

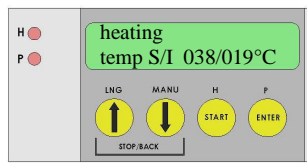

The pump and the heating are switched on until the programmed mashing in temperature has been reached. The target and actual temperatures are shown on the display.

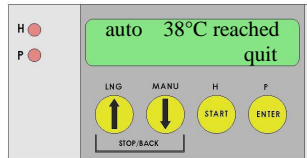

Once the mashing in temperature has been reached a signal tone is emitted; acknowledge this by pressing ENTER. This switches the pump off.

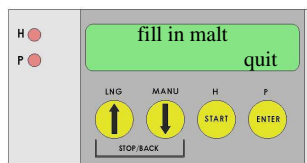

The malt pipe can now be inserted into the vessel, with the seal facing downwards. Ensure that the pipe is clean, centred and flush on the base. Then insert the first sieve screen (tubular sleeve upwards) into the malt pipe and place the first fine sieve on the screen. Now pour the entire roughly crushed malt into the malt pipe using a shovel and stir in thoroughly. Ensure that the malt is carefully added to the malt pipe so that nothing falls into the vessel, as this could block the pump.

Then insert the second fine sieve and the second filter plate (tubular sleeve upwards). To secure the malt pipe and clamp it down, fasten it with the bow and the wing nut while pressing it down.

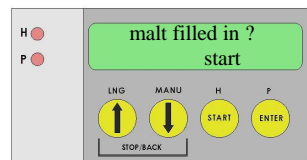

Once you have poured in the malt, press ENTER to acknowledge this. For safety reasons, you will receive the prompt "Malz eingefüllt?" (Malt added?). Press START to start the actual brewing procedure with the Braumeister. The pump and the heating switch on. The wort rises up in the pipe and overflows. The cycle has begun and the malt is washed out by means of transfer pumping in the next phases.

Protein rest

In the protein rest, the large protein molecules in the malt are split into small components. Protein rest is important for purification and full body, but especially for foam stability and carbon dioxide binding capacity of the beer. The temperature is around 52°C, and is maintained for 5-20 minutes, depending on the recipe programmed.

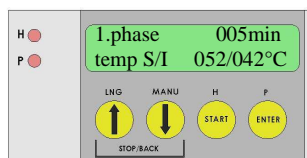

The display now shows the rest, target and actual temperatures as well as the time. After reaching the target temperature, the time indicator switches to a countdown of the time remaining (flashing) for this phase. All other phases are processed fully automatically. As for phase 1, the display also shows the corresponding times and temperatures.

Maltose rest:

In the second phase, the maltose rest, starch molecules are converted to fermentable sugar with the help of additional enzymes present in the malt. This phase is an important stage in the brewing procedure for alcohol formation, as the largest quantities of sugar are formed here. Extending the rest means gaining more sugar in the wort, which leads to a stronger beer. Shortening the time results in beer with a fuller body, due to the increased dextrins. The temperature is around 63°C and is maintained for a period of approx. 35 minutes. As is the case in the first phase, the control shows the relevant data in the display. All following processes (phase 2 to phase 5) are handled fully automatically by the control. During the entire mashing process, the pump is switched off briefly every 10 minutes (PUMP BREAK), to reposition the malt and thereby achieve a better yield. The lid of the Braumeister is in place to save energy.

Sugar rest 1:

In the third mashing phase additional starch components are split with the help of enzymes active at this temperature level, and liquified in the wort. The temperature is around 73°C and is also maintained for 35 minutes.

Sugar rest 2:

In the last phase the residual starches continue to saccharify, thereby forming even more unfermentable extracts, which give the beer slightly more body. The wort is heated to 78°C under continuous transfer pumping and then maintained at this temperature for 10-20 minutes. An iodine test can be used to determine whether the wort still contains residual starch. For this, allow a little wort to drip onto a white plate and add a little iodine. If the sample turns brownish red or yellow, sufficient saccharification has taken place. Where this is not the case, the last temperature level must be maintained for a longer period.

11.5 Purification

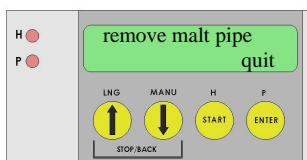
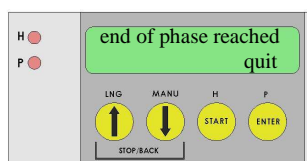

After completion of the programmed brewing phases, another signal tone is emitted. Press ENTER again to acknowledge it. The pump switches off and you are prompted to start purifying ("Malzrohr entnehmen" – Remove malt pipe). Purifying means separating the crushed malt from the beer wort. Purifying with the Braumeister is a relatively easy, fast and clean exercise, compared to many other home brewing methods, and represents a central concept of the Braumeister. Remove the wing nut including hold-down bow. Place the drip bow on the edge of the brewing vessel and use the lifting bow to carefully and slowly remove the malt pipe from the brewing vessel. Suspend the malt pipe from the support bow on the

lower support bolts to allow the beer wort to drop from the malt into the vessel. Loosen the last remaining extract by washing out the spent grains once more. This process is known as "sparging" (process not essential). This so-called sparging is performed by pouring water at 78°C (max 78°C!!! – not boiling water) into the top of the malt pipe. Remove the upper filter plate including screen cloth and use a long wooden spoon to pierce the spent grain a little so as to allow the "trapped" beer wort to continue running off or draining. During purification, keep the temperature constant

at the preset 78°C. After 15-20 minutes of purification, remove the malt pipe completely and dispose of the spent grain. For safety reasons, we recommend using heat-resistant gloves for this part of the process, as all components will have reached extremely high temperatures.

After removing the malt pipe acknowledge this by pressing ENTER again. The pump and the heating switch on again and the automatic process continues.

Once the purification process is complete, the wort content should be checked. This is important for ensuring the required original wort content of the wort, so as to be able to adjust the subsequent alcohol content of the beer as well. Fill a graduated cylinder (accessory) and determine the wort level at the time of sampling. For this, use the upper three filling level rings on the tie rod (15, 20 and 25 l or 45, 50, 55l). Estimate the levels between these markings correspondingly. For measuring the original wort using a beer spindle (accessory), first cool the wort sample to 20°C to ensure an exact measurement. A water bath with ice cubes or similar is suitable for this. However, as the original wort is proportional to a certain liquid level, you do not need to wait until you have performed the measurement. Simply continue with the next phase of hops boiling and subsequently correct or adjust the original wort.

11.6 Hops boiling

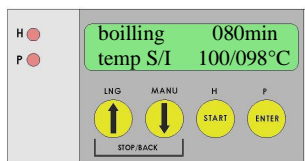

As described in the previous section, automatic brewing continues and hops boiling is started. The display again shows the time and temperature of the phase. As the target temperature of 100°C cannot always be reached, timing starts after a waiting period of 3 minutes after reaching at least 95°C. Where a sufficient bubbling does not occur at a

setting of 100°C, the target temperature can still be increased to 102°C during automatic operation. Wort is boiled in this phase. On the one hand, coagulable proteins are excreted and on the other hand wort is sterilised, which means that all bacteria that could potentially spoil the beer during fermentation are destroyed. As already mentioned in the description of the previous phase, the original wort can be adjusted by means of evaporated water or by topping up water. Hops is also added during the boiling period of 80-90 minutes, which imparts the required bitterness as well as the aroma to the beer. Depending on the recipe and taste, the amount of hops added can vary. Once the wort sample at the end of the previous phase has been measured in terms of original wort, it is set by means of the liquid level. Where the original wort content is equal to the target value, the level must be maintained right to the end by topping up boiling water. Where the original wort is too high, the wort is diluted by topping up with water and increasing the liquid level correspondingly. Care must be taken to replace evaporating water as well. Conversely, the liquid level must be decreased (through water evaporation) if the original wort content is too low, which leads to a higher concentration of sugar in the wort and consequently also to a higher alcohol content in the beer. It is essential that the boiling phase in the brewing vessel is performed without a lid. This prevents the wort from boiling over, but more importantly, is also necessary for hops boiling to ensure that all unwanted aromatic substances can evaporate from the hops, as they would otherwise impact negatively on the taste of the beer. Adding hops originally also served to better preserve the beer. Depending on the type of hops and bitter substance content, add the first batch of hops

to the boiling wort 10 to 15 minutes after boiling has started. The hops remains in the wort during the entire boiling period, as its substances only begin to unfold their effect after boiling for some time, thereby imparting the intended hops bitterness to the beer. The resins and oils in the hops are also released, which then ultimately gives the wort its malt flavour. You can then add another batch of hops approx. 10 min before the end of the boiling period, which merely adds to the flavour. Additional excretion of bitter substances is no longer possible in the remaining time. The hops amount varies according to recipe and beer type. The amount also depends on the hops itself, as the hops may vary according to cultivation location and year. Hops can be added in the form of pellets or dried hop blooms. The bitter substance content in beers is indicated in bitter units (BU) and is around 10-20 BU in wheat beers and 25-45 BU in pilsners. The bitter substance content of hops is indicated in % alpha acid, which can be between 2-4% (approx. 8% in pellets). The following formula can be used to calculate the hops quantity:

$$\text{Hops quantity in gram} = \frac{\text{Bitter units (BU)} \times \text{Litres of Beer} \times 10}{\% \text{ Alpha acid} \times \% \text{ Bitter substance concentration}}$$

A bitter substance concentration of 30% can be assumed for a total boiling period of 80-90 minutes.

Example:

A volume of 20l of wheat beer with a bitter substance content of 15 BU is to be brewed. The hops available has an alpha acid content of 3%. Thus, the following hops quantity is derived, which is added at the beginning of the boiling process. The hops added shortly before the end of the boiling process is not included in this calculation, as no more noteworthy bitter substance amounts are imparted to the wort in this short period of time.

$$\text{Grams of hops} = \frac{15 \text{ BU} \times 20 \text{ litres} \times 10}{3\% \times 30\%} = 33 \text{ g}$$

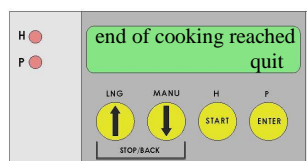

Once the boiling time has elapsed, another signal tone is emitted, indicating the end of the brewing procedure. Press ENTER to acknowledge. The heating switches off.

11.7 Cooling

From now on, it is essential that you work in absolutely sterile conditions, as any contamination through bacteria in the air or through unclean devices during all subsequent work steps could lead to all your work being in vain. All devices used must be thoroughly cleaned or disinfected. Please see the notes in the chapter “Notes on hygiene”.

Before inserting the cooling coil, we recommend stirring the hot wort thoroughly using a long wooden spoon. This creates a so-called whirlpool effect, which promotes the sinking of the trub in the wort, which means that the wort becomes clear.

In particular, the cooling process serves to cool the wort and to aid additional settling of all proteins and hops compounds released during boiling. This trub slowly settles on the base of the container, where it remains once the clear wort is drained. Avoid



stirring or moving the cooled wort, as this will cause the settled trub to whirl up again and also flow into the fermentation vessel. We recommend using a so-called wort cooler (cooling coil – see accessories), which is placed into the wort immediately after the boiling process, and is disinfected as well as this manner. Cooling is achieved by means of cold water. The water that flows through the cooling coil draws the heat from the wort and cools it to the required temperature of 20°C in 40 – 50 minutes. Caution: To start off with, the water at the outlet of the wort cooler is still close to boiling temperature (scalding risk), which can be re-used for cleaning activities at a later stage. It is especially important to cool the wort quickly between 40° and 20°, as it is particularly susceptible to infection in this range. Once the wort has cooled to 20°C, remove the cooling coil carefully from the vessel and drain the beer wort into a disinfected fermentation vessel (see accessories) via the drainage tap. However, first decant approx. 6% (1,5l for 20l or 3l for 50l wort) into a sealable container and freeze. This is added to the fermented beer at a later stage, so as to achieve secondary fermentation and sufficient formation of carbon dioxide in the filled bottles. Use a suitable clean pipe or funnel for decanting. The last litres are decanted by carefully tilting the Braumeister, taking care not to allow any trub to flow into the fermentation vessel as well. The fermentation vessel or container should be significantly larger than the quantity of wort to allow sufficient fermentation space and to prevent overflowing of the fermentation foam. The last remains and the trub at the base of the Braumeister can be disposed of. Please clean the Braumeister as quickly as possible after use so as to avoid surface drying. This facilitates the cleaning process considerably.

11.8 Main fermentation

Once the cooled wort has been filled into a fermentation vessel (30l/ 60l PE vessel with drainage tap – see accessories), add the yeast to the wort. We recommend using dry yeast as it is easy to add to the vessel. This is the phase in which you need to decide whether you would like to prepare bottom-fermented or top-fermented beer. Top fermented yeast requires a temperature of 5-23°C for the fermentation process, as opposed to bottom-fermented yeast, which is active at 4-12°C. Consequently, the addition of yeast is also dependent on the relevant recipe and the beer type desired. Wheat beer and Koelsch are top-fermented beers whereas bottom-fermented beers include Maerzen and Pilsner. Alcoholic fermentation of the beer is started by the activity of beer yeast organisms, which causes the fermentable sugar to be converted into alcohol and carbon dioxide. After adding the yeast, immediately seal the container with a lid and fermentation lock. Sulphuric acid should be filled into the fermentation lock so as to ensure that no foreign organisms enter the vessel. It is imperative that you perform this work step in absolutely sterile conditions as well to prevent the beer from becoming infected by foreign organisms. The vessel may never be completely sealed to allow the CO₂ resulting from the fermentation to escape. Place the vessel in a darkened room that has the correct temperature for the yeast. A fridge that is not set too low can be used for fermentation of bottom-fermented beer. For this reason, beginners are recommended to start with top-fermented beer types, as not everyone has an additional fridge at their disposal. Maintaining the temperature is extremely important. Temperatures that are too low cause the yeast cells to become active too slowly or not at all. Temperatures that are too high can lead to the yeast cells dying off. Fermentation should be active 6-12 hours after the yeast has been added; you can determine this by simply checking for escaping gas bubbles from the fermentation lock. Fermentation takes 2-4 days. Dark yeast spots may occur on the fermentation foam during the fermentation process. These can be removed by means of a sterile wooden spoon. Should you remove wort via the drainage tap during the main



fermentation period (e.g. for measurements using the beer spindle), immediately clean the tap and disinfect using a cotton-wool ball and sulphuric acid where necessary. This prevents surface drying and subsequent infection by inherent bacteria during decanting.

11.9 Maturation

During secondary fermentation or maturation, all sugars remaining from the main fermentation process and added sugars are fermented – causing the green beer to build up carbon dioxide, which is of significance for subsequent formation of foam, foam stability and freshness. The beer also matures to perfection as regards taste, and a natural clarity is achieved as well. As soon as fermentation is complete (no escaping of fermentation gases), the beer can be decanted. For this, prepare the following: maturation containers/ bottles and defrosting of wort.

The most ideal option available to you is secondary fermentation in bottles, which is also the preferred method by most hobby brewers. Additional options are various pressure-resistant containers such as special 5l tins or real beer vessels and pressure vessels. Here too, it is important to work under sterile conditions. All devices must therefore be thoroughly cleaned and disinfected prior to use. When using flip-top bottles, we recommend using the following method of bottle sterilisation: Wash and clean the bottles thoroughly using warm water, to remove liquid and surface-dried remnants. Then place the bottles in the oven (allow space between the bottles, remove seals) and heat to 130°C. Maintain the temperature for a maximum of 5 minutes. Allow the bottles to cool in the oven. Use boiling water to disinfect the rubber seals separately. Once the bottles are cool, immediately seal them hermetically; the bottles are now ready for filling. These preparations should take place during the fermentation process or even earlier to ensure that you do not inflict unnecessary pressure on yourself on the day of bottling, and can concentrate on more important matters. You could also use larger bottles to keep the effort involved in cleaning and filling to a minimum.

The defrosted wort is then added carefully to the green beer in the fermentation vessel 1-2 hours before bottling. This allows whirled up trub to settle again. Attach a pipe that reaches the base of the bottles to the drainage tap for bottling. In this way, you can avoid extreme frothing and ensure that loss of carbon dioxide is kept to a minimum. Fill the bottles 90-95% (fermentation space) and seal immediately. Also take care not to whirl up and decant the sediment in the fermentation vessel. After bottling, store the beer for 1-2 days at the same temperature as used in the main fermentation. Then store at a low temperature where possible. Important: During secondary fermentation, it is essential to check the bottles for excess pressure after approx. 12 hours and again in the first 2-3 days, and to briefly ventilate once where required, so as to avoid excess pressure from the CO₂. Store the bottles in an upright position so that any trub can settle on the base. This type of beer production results in naturally cloudy beer. In days gone by, nutritious beer was always naturally cloudy and is today also still preferable, as it contains valuable B vitamins bonded on the yeast cells. The first tasting can take place after a storage period of 2-4 weeks. Slightly longer storage periods result in an even more mature taste.

Your home-brewed beer is now ready. Serve cold and enjoy with your friends!
Cheers!

12 Brewing example/ brief instructions

The following example serves to illustrate your first brewing procedure with the Braumeister on a step-by-step basis using an actual recipe:

Beer type: Pale wheat beer/ top-fermented
 Beer quantity: 20l/ 50l ready-to-drink beer
 Original wort: 11-12°Plato

Ingredients:

- 4.5/ 10 kg **roughly** crushed brewing malt (50% wheat malt, 50% barley malt, and a touch of caramel malt where required)
- 30l/ 60l medium-hard brewing water or tap water (23l/ 53l to start off with and the remainder for topping up)
- 30g/ 75g hops with 4% alpha acid (approx. 2/3 immediately after start of boiling and approx. 1/3 a few minutes before end of boiling)
- Top-fermented dry yeast



Procure ingredients according to above indications.

Clean the Braumeister and place securely in brewing location.

Also clean all additional equipment required, such as malt shovel, wooden spoon, wort hydrometer, cooling coil, fermentation vessel including accessories etc, and have readily accessible.

Programming the recipe – Press ENTER for 1 second. You can set times and temperatures according to recipe in programming mode. A suitable standard recipe is already stored. Confirm all values by means of ENTER to return to the basic setting. Start the brewing automation by pressing START for 1 second. The Braumeister guides you through the following brewing procedure.



Add 23l/ 53l brewing water – to approx. 2 cm below the upper marking on the tie rod or filling level indicator. Follow the instructions of the brewing control by pressing ENTER to acknowledge that water has been added. Venting of the pump takes place automatically, followed by heating up to the programmed mashing-in temperature.



When the mashing-in temperature has been reached a signal tone is emitted; press ENTER to acknowledge. Then insert the malt pipe (with pulled-on seal facing downwards). Ensure that the seal is centred on the malt pipe and sits absolutely flush on the vessel base. Slide in the filter plate to the lower edge (pipe facing up). Then insert the fine sieve (position at bottom of water).

Pour 4.5/ 9 kg malt into the malt pipe. Ensure that no malt is spilled, as this could block the pump.

Mix the malt in thoroughly using a wooden spoon and allow to swell for a few minutes. Then slide the second fine sieve onto the malt followed by the second filter plate (pipe facing up again). Position the hold-down bow and tighten well using the wing nut.



Then press START to continue automatic brewing. Lightly coloured brewing water rises up and spills over. The cycle has begun. The next brewing phases take place fully automatically, as programmed. During some of the brewing phases, the control causes a short pump break to reposition the malt. The display shows the actual and target temperatures as well as the remaining time, which is counted down once the target time has been reached (flashing).

Once the brewing phases are complete another signal tone is emitted; press ENTER to acknowledge. Remove the wing nut and hold-down bow. As all parts are extremely hot, we definitely recommend using kitchen gloves. Rest the hold-down bow on the vessel. Pull out the malt pipe using both hands and suspend from the lower bolts in the hold-down bow. Allow the malt to drain. Use the wooden spoon to pierce the malt several times to allow the beer wort to drain more effectively. Remove the malt pipe with the malt completely after 15-20 minutes.



Continue by pressing START, so as to start hops boiling. Do not close the lid. Avoid the hops boiling over. Add the first batch of hops of 20/ 50g 10 minutes after boiling point has been reached. Do not close the lid during hops boiling either. Steam must be able to escape. Top up evaporated water quantity or adjust original wort. Add the last batch of hops 10 minutes before end of boiling.

Stir the hot wort thoroughly (whirlpool effect) so as to purify it from the hot break. Then immediately place the cooling coil (accessory) into the centre of the vessel. Connect the coil to cold water and allow cooling to start. Caution: Boiling hot water initially flows through the coil. Cool beer wort to 20°C. From now on ensure sterility so as to avoid infection. Allow the excreted trub to settle on the base. Avoid vibrations. Duration approx. 25 min.



Fill the wort into a sterile 30 l plastic vessel using a funnel (see image) or pipe. First disinfect the vessel and filling aids with sulphuric acid. Do not allow sediment on the base of the vessel to flow out.

Add 7g dry yeast to the wort and seal fermentation vessel by means of the fermentation lock filled with sulphuric acid.

Store the container in a dark location at 16-20°C. Fermentation begins after approx. 12 hours. Remember: Fill 1.5/ 3l wort into a container and freeze (before adding yeast).

Fermentation duration: 3-5 days. Fermentation is complete when no more fermentation bubbles escape. Prepare the maturation bottles while fermentation is in progress. Sterilise flip-top bottles in the oven at a temperature of 130°C and allow to cool in the oven. Boil the rubber seals.



Defrost frozen wort and carefully pour into fermentation vessel 1 hour before decanting. First remove a little foam from the top using a ladle. Do not move the vessel again before decanting. Fill into bottles, kegs or maturation vessels (accessory) using a pipe. Do not fill bottles more than 90-95%. Allow bottles to stand at even temperature for 1-2 days and ventilate briefly on a daily basis (only in case of excess pressure). Then allow the beer to mature a further 3-4 weeks at a temperature of 10-15°C.



Cheers !!!

You can find additional recipes at www.speidels-braumeister.de



13 Brewing faults/ troubleshooting

Do not repair the device yourself. Rather seek an authorised specialist. To avoid risks, defective controls/mains cables or other electrical components may only be replaced or repaired by the manufacturer, our customer service or a person with similar qualifications.

Problem when brewing:	Troubleshooting
<i>Wort fountains shoot up during circulation</i>	Malt is crushed too finely Crush malt yourself where necessary (only crack open malt)
<i>Pump blocked</i>	More thorough insertion of fine sieve/filter cloth and filter plates. Take more care when pouring into malt pipe. No malt into vessel!
<i>Pump makes noises</i>	Pump closed too tightly (hand tighten only) or not properly vented.
<i>Reaching correct temperature takes too long</i>	Close lid during heating up period. Place Braumeister in wind-protected location.
<i>Condensation forces its way out of the lid</i>	Set up Braumeister in vertical position.
<i>Circulation process does not start</i>	Check whether pump is operating and vented. Check even positioning of malt pipe on vessel base and proper sealing.
<i>Wort flows too slowly or not at all during purification</i>	Use wooden spoon to pierce malt from top to bottom filter plate several times. Malt is crushed too finely -> Break open corns only, do not grind finely.

Problem with beer:	Troubleshooting
<i>Beer smells and tastes sour</i>	Ingress of bacteria: pour beer away. Work more thoroughly in cold-process area. Brewing times possibly not long enough, therefore excess starch residue in beer. Top-up water too hot (> 80°C)
<i>Alcohol content too high</i>	Decrease original wort content by adding water during hops boiling.
<i>Alcohol content too low</i>	Increase original wort content by increasing boiling time (water evaporation).
<i>Various foreign odours</i>	More cleanliness. Avoid contact with mould and non-precious metals. Avoid light in beer storage area.
<i>Fermentation does not start</i>	Add more yeast. “Activate” yeast. Check fermentation temperature. Ventilate wort by stirring.
<i>Beer is cloudy</i>	Store beer for longer period. Colder conditions for secondary fermentation. Do not decant precipitate.



<i>Carbon dioxide too low</i>	Too much carbon dioxide lost during decanting or through pipe. Freeze more wort and add prior to decanting.
<i>Carbon dioxide too low – beer foams over</i>	Pressure too high – ventilate flip-top bottles more frequently. Decanting took place too soon – fermentation was not complete. Too much wort added prior to decanting.
<i>Poor foam stability</i>	Too little carbon dioxide. Decrease protein rest. Higher temperature for mashing in. Remove hot break more thoroughly. Lower temperatures for fermentation.
<i>Yield too low</i>	Stir in malt more thoroughly Malt quantity too high; adding more malt than recommended optimal amounts leads to strongly compressed malt and poor extraction.

14 Legal aspect of home brewing

Hobby brewers who produce beer in their own residence for personal consumption may produce up to 200 l beer per year, tax-free. This beer may not be sold. Hobby brewers must provide the chief customs office responsible with notification prior to starting the first brewing procedure. The following is stipulated in the Ordinance on the Implementation of the German Beer Tax Law (BierStV):

§ 2 – Production by home and hobby brewers

(1) Beer produced by home and hobby brewers in their own residences exclusively for own consumption and that is not sold is exempt from tax up to a quantity of 2 hectolitres per calendar year. Beer produced by home brewers in non-commercial communal breweries shall be deemed to have been produced in the residences of the home brewers.

(2) Home and hobby brewers are obliged to notify the chief customs office of the start of production and the production location in advance. The notification must indicate the planned quantity of beer to be produced in a calendar year. The chief customs office may grant concessions.

You can find the customs office responsible in terms of notification of your first brewing procedure at www.zoll-d.de. The customs office can be notified by fax or by letter as follows, for example:

Address of Chief Customs Office	Address of Sender
	Date
Notification of production of beer in private household	
Dear Sir/Madam	
I intend brewing beer for personal consumption at my abovementioned address:	
<u>Production location:</u> (where different from Sender address)	
<u>Production date:</u>	
<u>Beer quantity:</u> 20 litres top-fermented wheat beer Original wort content approx. 11°Plato	
In calendar year XXXX I intend producing no more than 200 litres beer.	
Yours sincerely	



15 Brewing record

Basic data					
Date:		Start of brewing procedure – time:		End of brewing procedure – time:	
Recipe					
Malt kg – Hops g – Water l:					
Brewing procedure					
Procedure phase		Temperature		Duration	
Mashing in:					
1. Protein rest phase:					
2. Maltose rest phase:					
3. Sugar rest 1 phase:					
4. Sugar rest 2 phase:					
Iodine test:		Purification:		Replenishment – litres:	
ACTUAL wort content measurement:		°Plato:		Litres:	
TARGET wort content measurement:		°Plato:		Litres:	
Wort boiling:		Total duration:	1 st hops addition:	2 nd hops addition:	
Filtering:	Cooling:	Wort removal:	Decanting:	Wort content - °P:	Yeast addition:
Fermentation process/ after-fermentation process					
Start of fermentation – date:			Fermentation temperature:		
Decanting date – date:		Wort content - °P:	Wort addition:	Maturation vessel:	
Tasting					
Taste, colour, behaviour of foam, carbon dioxide, faults:					
Improvements					

16 Cleaning instructions

Fill with approx. 2 cm water via the heating coil and heat to ~ 35°C by means of manual control. Caution: Vent the pump by switching it on and off several times!

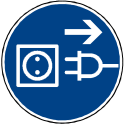

Then disconnect the Braumeister from the mains again.

You can now remove all brewing remnants from the inside of the container and the heating coil using a brush, ideally after each brew.



Basic cleaning also includes cleaning of the suction and pressure openings.

After cleaning the heating coil, inner wall of the container, and the suction and pressure openings, empty the Braumeister and rinse the entire container once more.

Then proceed with cleaning the pump (p. 24).

Open the pump:

You should be able to open the pump housing by hand. If this is not the case, please loosen the housing via the screw-cap using a small square of timber and a hammer.



The rotor ball in the interior of the pump then becomes visible.

Caution:

- Rotor ball may fall out!
- Damage to the rotor wings results in failure of the pump at a later stage!

Remove the rotor ball from the housing for cleaning. Any brewing remnants must be carefully removed so as not to block the bores.



The pump housing should also be cleaned. Then place the clean rotor ball back into the housing.

Finally, tighten the screw pump again – by hand only.

Accessory: Cleaning set (Item no.: 78027)





17 Guarantee conditions, handling a guarantee

Conditions:

- Statutory guarantee conditions apply. The guarantee period for users is reduced to the regulations applicable to commercial customers to the extent that they are making use of a device suitable for commercial use, including in part.
- Transmission of a copy of proof of purchase is a prerequisite for guarantee claims against us or one of our dealers. For verification of the guarantee refer to the note on handling a guarantee below.
- For quick processing of guarantee claims, please inform us immediately in writing upon noticing defects, and include a fault description and photos where applicable.
- No guarantee is given for defects due to non-adherence to the operating instructions, improper treatment or normal wear and tear of the device. Guarantee claims are also excluded in terms of brittle components or expendables such as seals or similar. Finally, guarantee claims are excluded where work is performed on the device by non-authorised parties.

Handling:

Should your device display any defects within the guarantee period, please inform us of your guarantee claim. The fastest and most convenient option is to return the device or the notice of defect to the dealer/agent responsible or directly to us:

E-Mail to: verkauf@speidel-behaelter.de

or fax to: 0049 – (0)7473 -9462-99

Please provide us with your **full address including contact details**. In addition we require the **type designation** of the device in question, a short **fault description including photos, where applicable**, the **purchase date (copy of invoice)** and the **dealer** from whom you purchased the new device.

After verifying your notification of defect, we will contact you as soon as possible to agree the next step. Please, under no circumstances, send us your device by Carriage Forward.











de	Sollte die beiliegende Betriebsanleitung nicht in einer für Sie verständlichen Sprache vorliegen, so kontaktieren Sie diesbezüglich bitte Ihren zuständigen Händler.
en	If the accompanying instructions are not in a language that you can understand, please contact your local dealer in this regard.
fr	Si les instructions accompagnant dans une langue qu'ils comprennent, vous donc s'il vous plaît contacter votre revendeur local.
es	Si las instrucciones que acompañan estar en un idioma que comprendan, que por favor contacte a su distribuidor local.
pt	Se as instruções que acompanham estar em uma linguagem que eles entendem, você por favor contacte o seu revendedor local.
pl	Jeśli instrukcje towarzyszące są w języku, który rozumieją, tak, proszę skontaktuj się z lokalnym dealerem.
no	Hvis instruksjonene som følger med være på et språk de forstår, du så ta kontakt med din lokale forhandler.
fi	Jos ohjeet mukana olevan he ymmärtävät, olet niin ota yhteyttä paikalliseen jälleenmyyjään.
sv	Om instruktioner vara på ett språk de förstår, behaga dig så kontakta din lokala återförsäljare.
da	Hvis anvisningerne ledsager være på et sprog, de forstår, så du bedes kontakte din lokale forhandler.
it	Se le istruzioni che accompagnano in una lingua che capiscono, ti prego pertanto di contattare il rivenditore locale.
el	Εάν οι οδηγίες που συνοδεύουν να είναι σε γλώσσα που κατανοούν, σας γι 'αυτό παρακαλώ επικοινωνήστε με τον τοπικό σας αντιπρόσωπο.
hu	Ha a mellékelt használati utasításnak kell olyan nyelven, amit megértene, akkor ezért kérjük, forduljon a helyi forgalmazóhoz.
nl	Als de instructies die bij in een taal die zij begrijpen, je zo kunt u contact opnemen met uw lokale dealer.
ro	În cazul în care instrucțiunile care însoțesc să fie într-o limbă pe care o înțelege, vă rugăm să vă contactați distribuitorul local.
ru	Если инструкции сопровождающих быть в понятном для них языке, вы поэтому, пожалуйста, обратитесь к вашему дилеру.
sk	Ak Návodý priloženej byť v jazyku, ktorému rozumie, si tak obráťte sa na miestneho predajcu.
sl	Če navodila, ki spremljajo, so v jeziku, ki ga razumejo, zato vas prosimo, obrnite na lokalnega prodajalca.
bg	Ако инструкциите, придружаващи се в разбираем за тях език, можете да се обърнете към местния дилър.
sr	Ако се прате упутства бити на језику који они разумеју, тако да вас молимо да се обратите свом локалном дистрибутеру.
hr	Ako upute prate se u jeziku koji razumiju, pa vas molimo da se obratite svojem lokalnom zastupniku.
cs	Pokud Návodý přiložené být v jazyce, kterému rozumí, jsi tak obraťte se na místního prodejce.
tr	talimatları anladıkları bir dilde olması eşlik ederseniz, bu nedenle yerel satıcınıza başvurun.
zh	如果指示随行在他们理解的语言，所以请您联系当地的经销商。
ja	命令は、彼らが理解できる言語になるに伴う場合は、そのお近くの販売店に連絡してください。
ko	지침 그들이 이해하는 언어에 동행하는 경우, 당신은 귀하의 지역 대리점에 문의하시기 바랍니다.
th	หากคำแนะนำการประกอบอยู่ในภาษาที่พวกเขาเข้าใจคุณตั้งนั้นโปรดติดต่อตัวแทนจำหน่ายในประเทศของคุณ
vi	Nếu các hướng dẫn đi kèm có trong một ngôn ngữ mà họ hiểu, bạn nên xin vui lòng liên hệ đại lý địa phương của bạn.